

Pressure and Vacuum FEEDTHRU Specs

MODEL	A	THREAD (NPTM)	B	LENGTH (INCHES)	C	HEX SIZE (INCHES)	MAX # HOLES	
							.125"D	.065"D
S-300	1/8		1.40		1/2		1	3
	1/4		1.40		9/16		1	3
	1/2		1.60		7/8		1	3
	1/4" WELD		1.60		0.540 RD		1	3
S-420	1/4		1.40		5/8		3	5
	1/2		1.60		7/8		3	5
	1/4" WELD		1.40		0.540 RD		3	5
	1/2" WELD		1.60		0.840 RD		3	5
S-570	1/2		1.85		7/8		5	10
	3/4		1.90		1 1/16		5	10
	1/2" WELD		2.15		0.840 RD		5	10
S-710	1/2		1.85		15/16		8	14
	3/4		1.90		1 1/16		8	14
	1/2" WELD		2.15		0.840 RD		8	14
S-830	3/4		1.90		1 1/16		10	16
	3/4" WELD		2.15		1.050 RD		10	16
S-930	3/4		1.90		1 3/16		14	24
	1" WELD		2.15		1.315 RD		14	24
S-1140	1		2.35		1 3/8		24	--
	1" WELD		2.35		1.315 RD		24	--

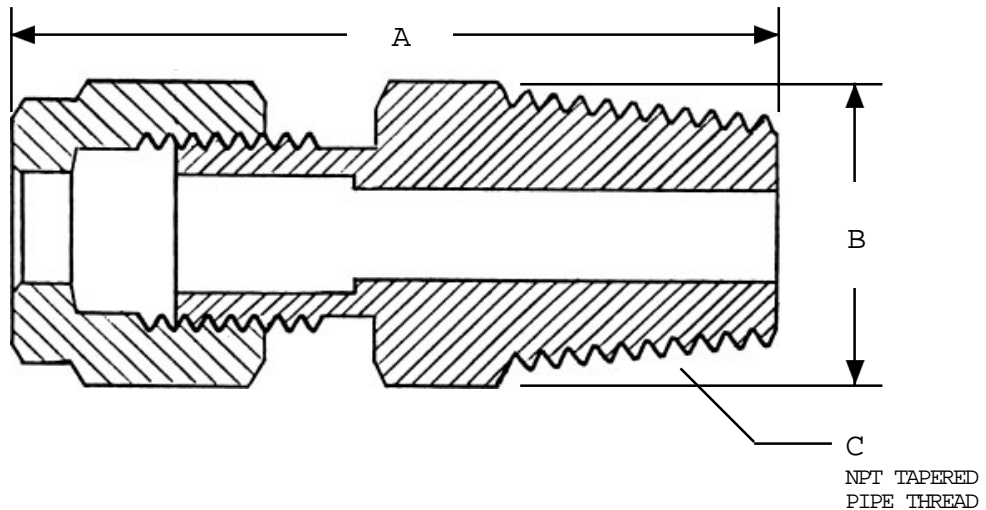

How to Order by Model Number

MODEL	NUMBER OF HOLES	HOLE SIZE	HOLE SHAPE	PIPE THREAD
S-XXXX — XX — XXX — OVal Round — X				
EXAMPLE:				
S-710 — 8 — 125 — OV — 3/4				